

DMN29 Series



Specification

TYPE	RATED						NO LOAD		STALL		WEIGHT	
	OUT PUT	VOLTAGE	TORQUE		CURRENT	SPEED	CURRENT	SPEED	TORQUE			
	W	V	mN·m	oz·in	A	r/min	A	r/min	mN·m	oz·in	g	lb
DMN29BA	3.0	12	7.8	1.11	0.42	3700	0.07	5000	30	4.17	90	0.20
DMN29BB	3.0	24	7.8	1.11	0.21	3700	0.05	5000	30	4.17	90	0.20

Outline

DMN29

■ DIMENSIONS Unit mm(inch)

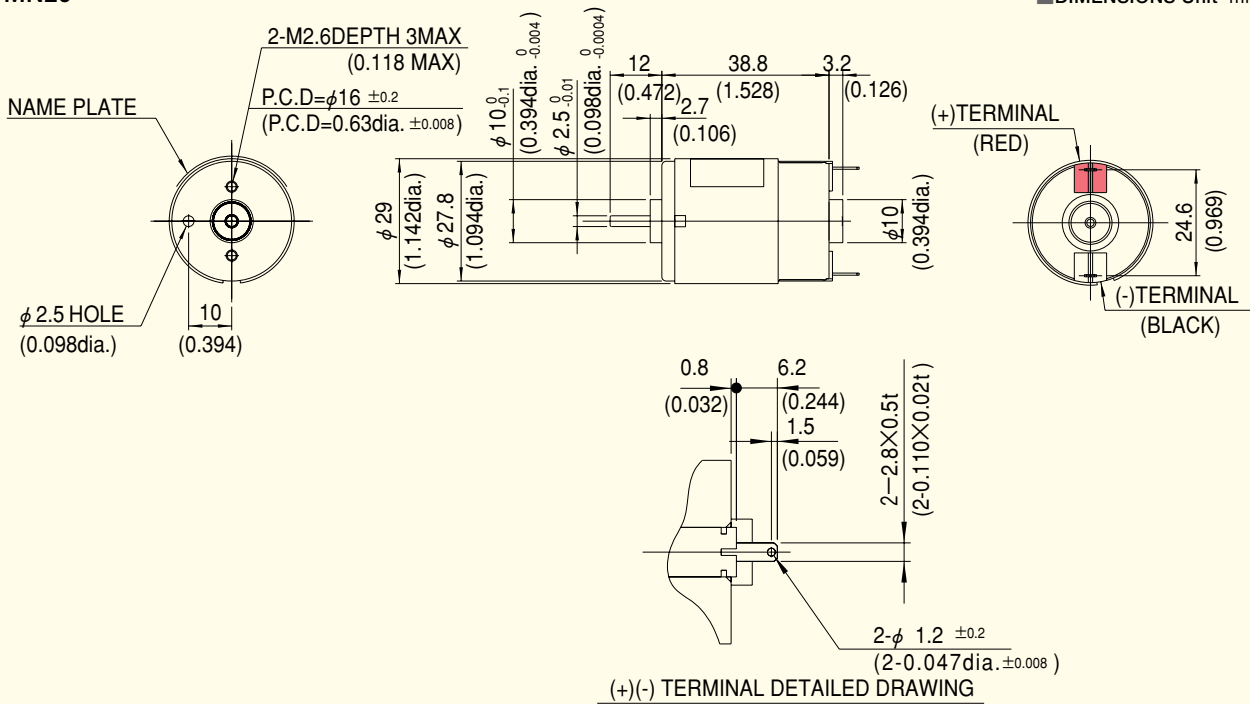

CURRENT, SPEED-TORQUE CURVE

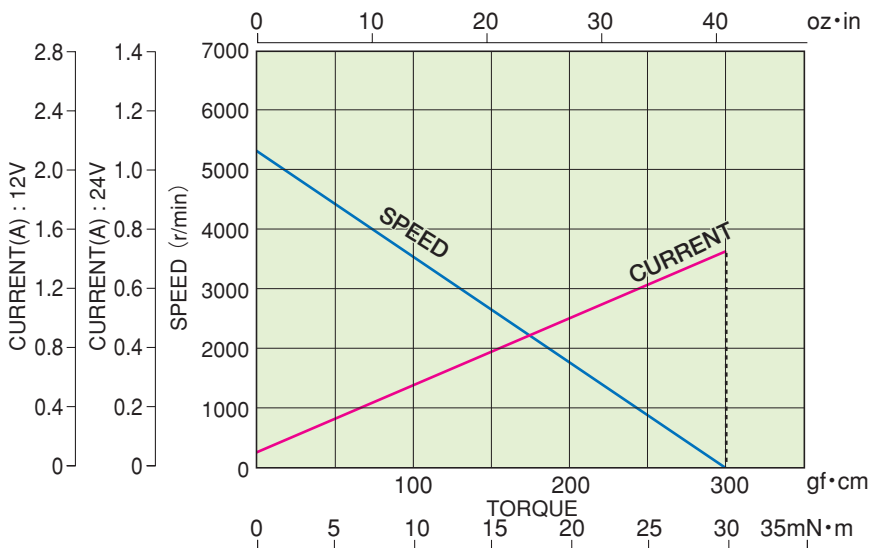

CONNECTION

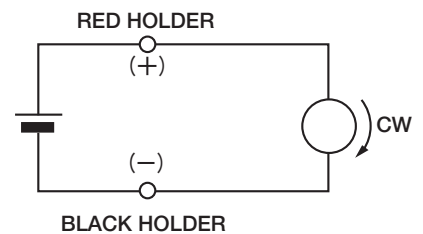

50G
Continuous Operation



Specification

GEAR RATIO	DMN29B50G□◇		
	RATED TORQUE		SPEED
	N·m	oz·in	r/min
9	0.057	8.07	411
18	0.11	15.3	206
27	0.15	26.9	137
36	0.21	29.2	103
54	0.31	43.1	68.5
72	0.41	58.4	51.4
96	0.49	72.3	38.5
144	0.74	104	25.7
192	0.98	139	19.3
256	0.98	139	15.8

※ Enter the required reduction ratio in the □.

※ □ Rotation of gearbox shaft is in reverse of rotation of motor.

※ Enter the required voltage A or B in the ◇.

6DG
Continuous Operation



Specification

GEAR RATIO	DMN29B6HP◇		
	RATED TORQUE		SPEED
	N·m	oz·in	r/min
3	0.019	26.4	1233
3.6	0.023	32.0	1028
5	0.032	44.5	740
6	0.038	54.3	617
7.5	0.048	68.5	493
9	0.057	8.07	411
12.5	0.079	11.3	296
15	0.10	13.5	247
18	0.11	15.3	206
25	0.14	19.5	148
30	0.17	2.6	123
36	0.21	29.2	103
50	0.29	40.3	74.0
60	0.34	48.7	61.7
75	0.43	59.8	49.3
90	0.51	72.3	41.1
100	0.57	80.7	37.0
120	0.69	97.4	30.8
150	0.77	109	24.7
180	0.93	131	20.6
225	0.98	136	17.3
250	0.98	139	16.0
300	0.98	139	13.9
360	0.98	139	12.0
450	0.98	139	9.9
500	0.98	139	8.9
600	0.98	139	7.6
750	0.98	139	6.2
900	0.98	139	5.2
1500	0.98	139	3.2
1800	0.98	139	2.7

※ Enter the required reduction ratio in the □.

※ □ Rotation of gearbox shaft is in reverse of rotation of motor.

※ Enter the required voltage A or B in the ◇.

Outline

DMN29B50G□◇ WEIGHT:230g 0.51lb

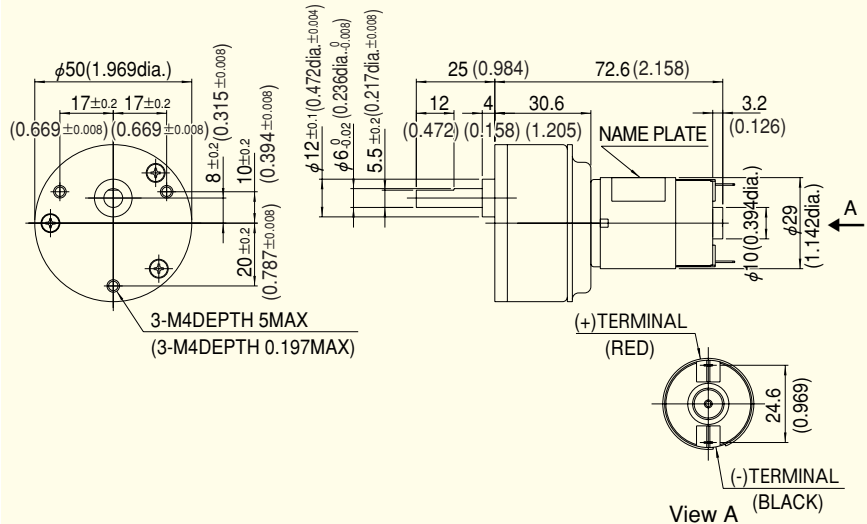

Outline

DMN29B6HP◇+6DG□ WEIGHT:350g 0.77lb

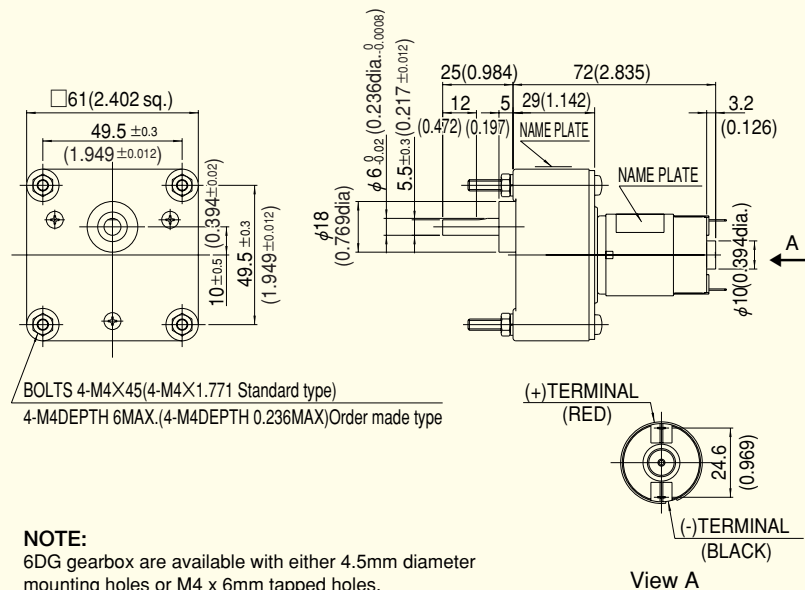

NOTE:

6DG gearbox are available with either 4.5mm diameter mounting holes or M4 x 6mm tapped holes.

- Gearboxes with 4.5mm diameter mounting holes are available from stock.

When ordering, please write the motor model and gearbox model numbers separately, as in the following example:

DMN29B6HP◇ (Pinion shaft motor)

6DG□ (Gearbox)

- Gearboxes with M4 x 6mm tapped mounting holes are available on request.

When ordering, please write the combine motor and gearbox model,

as in the following example : DMN29B6H□◇

- Enter the required reduction ratio in the □.
- Enter the required voltage A or B in the ◇.